



Treatment and Traction Tables



Introduction

Chattanooga is the world's largest manufacturer of rehabilitation equipment for treating musculoskeletal, neurological and soft tissue disorders. For over six decades, Chattanooga has set a benchmark for leadership, reliability and excellence. Our products contribute to better treatment outcomes in hospitals, clinics and home settings worldwide. We lead the rehabilitation industry by example, and through continuous innovation, provide real world solutions for clinicians and their patients.

As the world's leading brand in rehabilitation, Chattanooga is sold in over 80 countries worldwide. Chattanooga distributors and customers are supported by a highly trained and seasoned team of personnel who oversee new product development, product training and education, order placement, product delivery, and after sales service in addition to providing dedicated sales and marketing support.

Chattanooga is a brand of DJO Global Inc. DJO Global provides solutions for musculoskeletal health, vascular health and pain management. Our products help prevent injuries or rehabilitate after surgery, injury or from degenerative disease, enabling patients to regain or maintain their natural motion.

Visit www.DJOGlobal.com/chattanooga



AIRCAST

 chattanooga

 CMFV

 Compex

 djosurgical

 DONJOY

 Dr. Comfort

 PROCARE

Contents

Montane® Alps 5 Section Table	3	ADP 400 Traction Table	13
Montane® Atlas 3 Section Table	4	TTFT-200 Fixed Height Traction Table	14
Montane® Tattras 2 Section Table	5	TTET-200 Electric Hi-Lo Traction Table	15
Montane® Taurus Bobath Table	6	TX® Traction Unit	16
Montane® Colombia 2 Section Table	7	Traction Accessories	17
Adapta® Summit 7-Section Treatment Platform	9	Saunders® Cervical Traction	19
Adapta® Summit 3-Section Treatment Platform	10	Saunders® Lumbar Traction	20
Adapta® Mesa 2-Section Treatment Platform	11		
ADP 300 Treatment Table	12		



Treatment and Traction Tables

The foundation for any musculoskeletal assessment and treatment is the treatment table. It is also one of the most significant and long standing investments the practitioner will make. The treatment table is one of the foundations of the clinic's style and helps define the atmosphere of the practice. With more than 60 years experience in the rehabilitation arena, Chattanooga remains the practitioner's partner in design and equipment. Chattanooga is proud to present our new and expanded line of treatment tables, offering a broader range of products and price options. From multi-section tables, Bobath treatment tables, to a solid fixed table and offers the practitioner real table solutions.

Montane® Treatment Tables



The Pinnacle of Quality, Craftsmanship and Innovation.



Multilayer padding with specially selected density creates a synergy of ideal resistance for the practitioner and comfort for the patient.

High-performance, multidirectional casters and one central brake system allows for easy mobility of the table when not in use.

Ultra-quiet actuator and gas springs powerfully lift patients.

3322101 Alps 5 Section Table

Step up to the Montane difference.

Your table is the core of your practice, and with Montane, you have a trusted partner. Every detail has been designed, engineered and crafted to elegant, exacting standards, delivering a refined experience that maximizes patient comfort while optimizing practitioner access and ease of operation.



Proprietary Hallotronic® technology offers enhanced reliability.

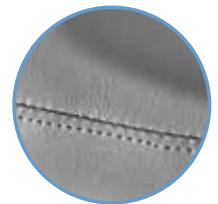

Premium upholstery in tasteful colors. Quality workmanship down to the detailed stitching.



Steel is laser cut, coated with a high quality powder coating and features extra-strong, precision robotic welds.

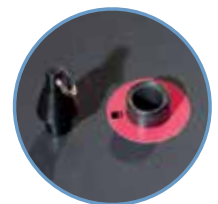

Electric Safety Box offers added security; allows practitioner to disable the mechanics when not in the room.



Generous height adjustment range from 19-40 inches.

Montane® Alps 5 Section Table



Features

Montane® Alps 5 Section Table

- 5 section treatment table includes fold down segments in head section
- Electric high/low height adjustment from 19" to 40" (49 to 101 cm) for easy and safe patient transfer and adjustment to the ideal working height for treatment
- Easy access foot switch, accessible from any position around the table 360°, for simple height adjustment
- Features smooth vertical lift with a capacity up to 330 lbs (150 kg)
- Adjustable head support - Positive/Negative inclinations
- Face hole on head section with removable cushion
- Side brackets for stabilizing belts are standard equipment
- Gas springs assist in the adjustment of head and foot sections

Table Articulations

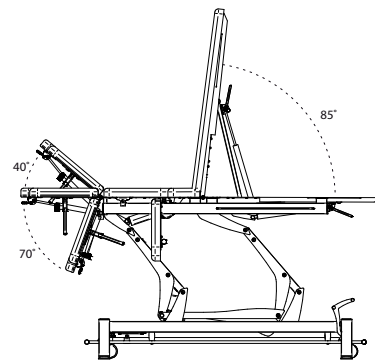
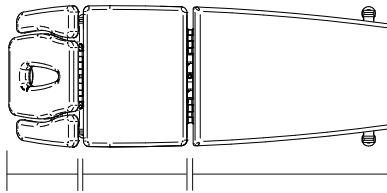

Ordering Information

Item#	Description
Montane® Alps 5 Section Table	
3551102US	Alps Blue 5 Section
3551106US	Alps Gray 5 Section
3551107US	Alps Graphite Gray 5 Section

Technical Specifications

Montane® Alps 5 Section Table	
Mains Power:	120 V / 60 Hz
Standby Consumption:	3.5 W
Input:	120 V / 1.9 A / 60 Hz
Weight:	242 lbs (110 kg) plus 66 lb pallet when shipping
Dimensions*:	79" X 27" x 19-40" (201 x 69 x 49 - 101 cm)
Shipping Dimensions*:	86" x 33" x 30" (219 x 84 x 75 cm)
Lifting Capacity:	330 lbs (150 kg)
Electrical Safety Class:	Class II, Type B
Safety Tests:	Meets Directive 93 / 42 / EEC, Certified to CAN CSA Standard C22.2 No. 6011-M90x/A2

* Dimensions are listed as L x W x H

Color Options

Montane® Alps 5 Section Table

BLUE	GRAY	GRAPHITE
------	------	----------

This color chart is produced within the limitations of lithographic color printing and is intended as a general guide only.

Montane® Atlas 3 Section Table



Ordering Information

Item#	Description
Montane Atlas 3 Section Table	
3531102US	Atlas Blue 3 Section
3531106US	Atlas Gray 3 Section
3531107US	Atlas Graphite Gray 3 Section

Technical Specifications

Montane Atlas 3 Section Table	
Mains Power:	120 V / 60 Hz
Standby Consumption:	3.5 W
Input:	120 V / 1.9 A / 60 Hz
Weight:	242 lbs (110 kg) plus 66 lb pallet when shipping
Dimensions*:	79" x 27" x 19"-40" (201 x 69 x 49 – 101 cm)
Shipping Dimensions*:	86" x 33" x 30" (219 x 84 x 75 cm)
Lifting Capacity:	330 lbs (150 kg)
Electrical Safety Class	Class II, Type B
Safety Tests:	Meets Directive 93 / 42 / EEC, Certified to CAN CSA Standard C22.2 No. 6011-M90x/A2
* Dimensions are listed as L x W x H	

Color Options

Montane Atlas 3 Section Table		
BLUE	GRAY	GRAPHITE

This color chart is produced within the limitations of lithographic color printing and is intended as a general guide only.



Features

Montane Atlas 3 Section Table

- 3 section treatment table
- Electric high/low height adjustment from 19" to 40" (49 to 101 cm) for easy and safe patient transfer and adjustment to the ideal working height for treatment
- Easy access foot switch, accessible from any position around the table 360°, for simple height adjustment
- Features smooth vertical lift with a capacity up to 330 lbs (150 kg)
- Adjustable head support - positive and negative inclinations
- Face hole on head section with removable cushion
- Side brackets for stabilizing belts are standard equipment
- Gas Springs assist in the adjustment of head and foot sections

Table Articulations

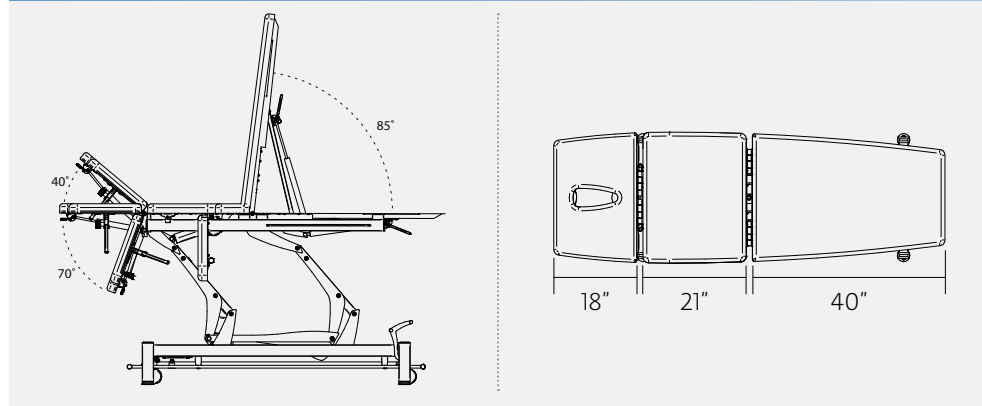

Montane® Tatras 2 Section Table



Features

Montane Tatra 2 Section Table

- 18" (46cm) head section
- Electric high/low height adjustment from 19" to 40" (49 to 101 cm) for easy and safe patient transfer and adjustment to the ideal working height for treatment
- Easy access foot switch, accessible from any position around the table 360°, for simple height adjustment
- Features smooth vertical lift with a capacity up to 330 lbs (150 kg)
- Gas springs assist in the adjustment of the head section
- Adjustable head support - positive and negative inclinations
- Face hole on head section with removable cushion
- Side brackets for stabilizing belts are standard equipment

Table Articulations

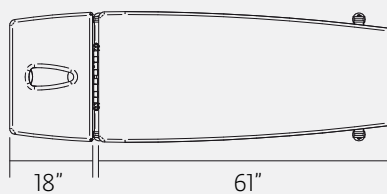
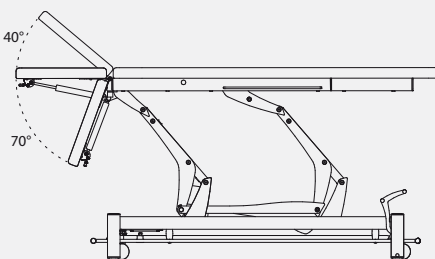

Ordering Information

Item#	Description
Montane Tatra 2 Section Table	
3521102US	Tatra Blue 2 Section
3521106US	Tatra Gray 2 Section
3521107US	Tatra Graphite Gray 2 Section

Technical Specifications

Montane Tatra 2 Section Table	
Mains Power:	120 V / 60 Hz
Standby Consumption:	3.5W
Input:	120 V / 1.9 A / 60 Hz
Weight:	242 lbs (110 kg) plus 66 lb pallet when shipping
Dimensions*:	78" x 27" x 19"-40" (198 x 69 x 49 - 101 cm)
Shipping Dimensions*:	86" x 33" x 30" (219 x 84 x 75 cm)
Lifting Capacity:	330 lbs (150 kg)
Electrical Safety Class	Class II, Type B
Safety Tests:	Meets Directive 93 / 42 / EEC, Certified to CAN CSA Standard C22.2 No. 6011-M90x/A2

* Dimensions are listed as L x W x H

Color Options

Montane Tatra 2 Section Table

BLUE	GRAY	GRAPHITE
------	------	----------

This color chart is produced within the limitations of lithographic color printing and is intended as a general guide only.

Montane® Taurus Bobath Table



Ordering Information

Item# Description

Montane Taurus Bobath Table

3581102US	Taurus Blue 2 Section
3581106US	Taurus Gray 2 Section
3581107US	Taurus Graphite Gray 2 Section

Technical Specifications

Montane Taurus Bobath Table

Mains Power:	120 V / 60 Hz
Standby Consumption:	3.5 W
Input:	120 V / 1.9 A / 60 Hz
Weight:	319 lbs (145 kg) plus 110 lb pallet when shipping
Dimensions*:	79" x 47" x 19"-40" (201 x 119 x 49 - 101 cm)
Shipping Dimensions*:	86" x 53" x 30" (219 x 134 x 75 cm)
Lifting Capacity:	330 lbs (150 kg)
Electrical Safety Class	Class II, Type B
Safety Tests:	Meets Directive 93 / 42 / EEC, Certified to CAN CSA Standard C22.2 No. 601.1-M90x/A2

* Dimensions are listed as L x W x H

Color Options

Montane Taurus Bobath Table

BLUE

GRAY

GRAPHITE

This color chart is produced within the limitations of lithographic color printing and is intended as a general guide only.



Features

Montane Taurus Bobath Table

- 2 section Bobath treatment table
- Extra wide patient surface and undercarriage
- Electric high/low height adjustment from 19" to 40" (49 to 101 cm) for easy and safe patient transfer and adjustment to the ideal working height for treatment
- Easy access foot switch, accessible from any position around the table 360°, for simple height adjustment
- Features smooth vertical lift with a capacity up to 330 lbs (150 kg)
- 2 section head support adjusts to 85° positive inclination for treatment
- Gas springs assist in the adjustment of head section

Table Articulations

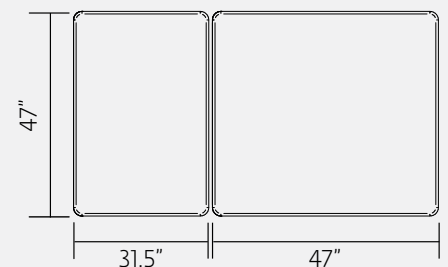
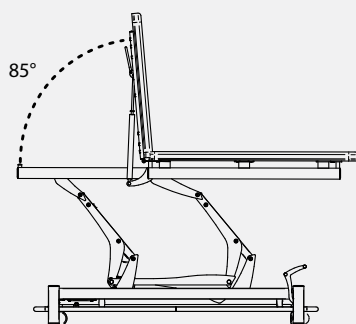

Montane® Colombia 2 Section Table



Shown with optional paper roll holder

Features

Montane Colombia 2 Section Table

- 2 section fixed table for examination and treatment
- Head section manually adjusts up to a 45° positive inclination
- Solid high-quality fixed table constructed to ensure maximum stability
- Paper roll holder (optional equipment)

Accessories



Table Articulations

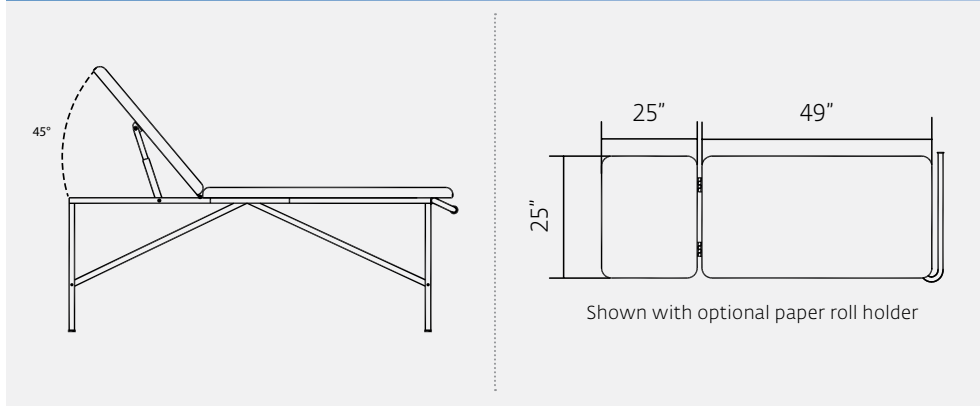

Ordering Information

Item#	Description
-------	-------------

Montane Colombia 2 Section Table	
3595100	Colombia Cream 2 Section Fixed Table
3595101	Colombia Beige 2 Section Fixed Table
3595108	Colombia Black 2 Section Fixed Table

Optional Accessories

A	371007	Paper Roll Holder - Fixed Height Tables
A	371008	Paper Roll Holder- 2, 3, and 5 Section Electric Tables
B	371102	Manual Traction Supports - Blue
B	371106	Manual Traction Supports - Gray
B	371107	Manual Traction Supports - Graphite

Replacement Part

C	15-0127	Magnetic Lock Key
---	---------	-------------------

Technical Specifications

Montane Colombia 2 Section Table	
Head Angle Adjustment:	0-45°
Maximum Weight Capacity:	330 lbs (150 kg)
Weight:	68 lbs (31 kg)
Dimensions*:	74" x 25" (189 x 64 cm)
Shipping Dimensions*:	75" x 26" x 10" (190 x 65 x 15 cm)
Capacity:	150 kg (330 lbs)

Paper Roll Holder for use with paper of a maximum width of 23" (60 cm)

* Dimensions are listed as L x W x H

Color Options

Montane Colombia 2 Section Table		
----------------------------------	--	--

CREAM	BIERGE	BLACK
-------	--------	-------

This color chart is produced within the limitations of lithographic color printing and is intended as a general guide only.

A better treatment platform takes shape.



3322101 Adapta Summit 7-Section Treatment Platform, PosturFlex, Pacific Blue

Platforms tailored to you and your patient

The Adapta® Mesa and Adapta® Summit treatment platforms give you multiple options so you can select what works for you. Need a seven section platform? How about a two or three section? The choice is yours. Using the motorized PosturFlex option to “peak” the center of the table helps accommodate patients who have difficulty lying flat. You can increase flexion or extension to add to the patient’s comfort without fumbling for bolsters, towel rolls or pillows and gradually bring them back to a flat position when treatment is over. Also included are: gas-assist movable sections and a retractable, integrated, EZ Lift caster system that makes moving the platform a cinch. Two-year warranty on cushions. Three-year warranty on base frame and motor.



PosturFlex (optional on Summit 3 and 7)

- Peak the center of the table to accommodate a variety of patients
- Increase flexion or extension to add to the patient’s comfort and gradually bring them back to a neutral position

Adapta® Summit 7-Section Treatment Platform



Features

Adapta® Summit 7-Section Treatment Platform

- 7 section treatment platform
- Electric high/low from 18" to 37" controlled by foot pedals accessible from all sides of the table
- Independent positioning of the pivoting head and arm sections
- Fold away side panels allow easy access to cervical and shoulder region
- Gas-assist elevates the foot section with the quick-release grab bar
- The leg cushion can be raised to any angle desired up to 80°
- Patient positioning with a hint of cushion contouring within the i-skin foam
- Dual-lever retractable caster system
- Engage the optional motorized postural drain with the push of a button
- Easily convert to Trendelenburg position with a quick raise of the gas-assisted grab bar
- Two-year warranty on cushions. Three-year warranty on base frame and motor



Head section adjusts positively and negatively for cervical manipulation and massage



Ergonomic shoulder wing and armrest adjustment for optimal spine positioning



Trendelenburg position



Optional Posturflex



Contoured patient surface for comfort in lying position



Segmented support system allows positioning from lying to reclining to sitting

Ordering Information

Item#	Description
Summit 7-Section Treatment Platform	
3321101	Pacific Blue
3321102	Midnight
3321103	Sand
3321105	Maroon
3321106	Terra Cotta
3321107	Chocolate
3322101	PosturFlex, Pacific Blue
3322102	PosturFlex, Midnight
3322103	PosturFlex, Sand
3322105	PosturFlex, Maroon
3322106	PosturFlex, Terra Cotta
3322107	PosturFlex, Chocolate

Technical Specifications

Adapta® Summit 7-Section Treatment Platform	
Mains Power:	100-240 V, 50-60 Hz
Standby Consumption:	7 W
Input:	120 V / 17 A / 60 Hz
Weight:	310 lbs (141 kg)
Dimensions*:	79" x 28" x 18"-37" (200 x 69 x 45.7 - 94 cm)
Lifting Capacity:	450 lbs (204 kg)
Electrical Safety Class:	Class II, Type B
Safety Tests:	IEC/UL/EN 60601-1, IEC 60601-1-1, IEC 60601-1-2, CAN/USA C22.2 No. 601.1-M90 w/ A2

* Dimensions are listed as L x W x H

Color Options

Summit 7-Section Treatment Platform		
MIDNIGHT	CHOCOLATE	MAROON
PACIFIC BLUE	TERRA COTTA	SAND

This color chart is produced within the limitations of lithographic color printing and is intended as a general guide only.

NOTE: 60000 – Table Paper Holder 20" (51 cm) Wide (TRT and ADP) cannot be used with the Adapta Mesa or Summit Treatment Tables.

Lifting Capacity: 450 lbs (204 kg)

Adapta® Summit 3-Section Treatment Platform

Ordering Information

Item#	Description
Summit 3-Section Treatment Platform	
3320101	Pacific Blue
3320102	Midnight
3320103	Sand
3320105	Maroon
3320106	Terra Cotta
3320107	Chocolate
3323101	PosturFlex, Pacific Blue
3323102	PosturFlex, Midnight
3323103	PosturFlex, Sand
3323105	PosturFlex, Maroon
3323106	PosturFlex, Terra Cotta
3323107	PosturFlex, Chocolate

Technical Specifications

Adapta® Summit 3-Section Treatment Platform	
Mains Power:	100-240 V, 50-60 Hz
Standby Consumption:	7 W
Input:	120 V / 17 A / 60 Hz
Weight:	310 lbs (141 kg)
Dimensions*:	79" x 28" x 18"-37" (200 x 69 x 45.7 - 94 cm)
Lifting Capacity:	450 lbs (204 kg)
Electrical Safety Class:	Class II, Type B
Safety Tests:	IEC/UL/EN 60601-1, IEC 60601-1-1, IEC 60601-1-2, CAN/USA C22.2 No. 601.1-M90 w/ A2
* Dimensions are listed as L x W x H	

Color Options

Summit 3-Section Treatment Platform		
MIDNIGHT	CHOCOLATE	MAROON
PACIFIC BLUE	TERRA COTTA	SAND

This color chart is produced within the limitations of lithographic color printing and is intended as a general guide only.



Features

Adapta® Summit 3-Section Treatment Platform

- 3 section treatment platform
- Electric high/low from 18" to 37" controlled by foot pedals accessible from all sides of the table
- Gas-assisted head section pivots up and down independent of the chest section
- Gas-assist elevates the foot section with the quick-release grab bar
- The leg cushion can be raised to any angle desired up to 80 degrees
- Patient positioning with a hint of cushion contouring within the i-skin foam
- Dual-lever retractable caster system
- Engage the optional, motorised postural drain feature with the push of a button
- Easily convert to Trendelenburg position with a quick raise of the gas-assisted grab bar
- Two-year warranty on cushions. Three-year warranty on base frame and motor



Head section adjusts positively and negatively for cervical manipulation and massage

Segmented support system allows positioning from lying to reclining to sitting

Contoured patient surface for comfort in lying position

Optional Posturflex

Trendelenburg position

Adapta® Mesa 2-Section Treatment Platform



Features

Adapta® Mesa 2-Section Treatment Platform

- 2 section treatment platform
- Electric high/low from 18" to 37" controlled by foot pedals accessible from all sides of the table
- i-Skin cushions Integral Skin Foam patient surface
- Patients can be oriented toward either end of the table with dual face holes to manage the confines of a small clinic room
- Gas-assist elevates one section of the table with the quick-release grab bar. The cushion can be raised to any angle desired up to 80 degrees
- Dual-lever retractable caster system
- Unique cushion break in the center eliminates the need for wedges or pillows in seated position
- Two-year warranty on cushions. Three-year warranty on base frame and motor



Contoured patient surface for comfort in lying position



2-section support system allows positioning from lying to reclining to sitting



Ordering Information

Item#	Description
Adapta® Mesa 2-Section Treatment Platform	
3319101	Pacific Blue
3319102	Midnight
3319103	Sand
3319105	Maroon
3319106	Terra Cotta
3319107	Chocolate

Technical Specifications

Adapta® Mesa 2-Section Treatment Platform	
Mains Power:	100-240 V, 50-60 Hz
Standby Consumption:	7 W
Input:	120 V / 1.7 A / 60 Hz
Weight:	310 lbs (141 kg)
Dimensions*:	79" x 28" x 18"-37" (200 x 69 x 45.7 - 94 cm)
Lifting Capacity:	450 lbs (204 kg)
Electrical Safety Class:	Class II, Type B
Safety Tests:	IEC/UL/EN 60601-1, IEC 60601-1-1, IEC 60601-1-2, CAN/USA C22.2 No. 601.1-M90 w/ A2
* Dimensions are listed as L x W x H	

Color Options

Adapta® Mesa 2-Section Treatment Platform		
MIDNIGHT	CHOCOLATE	MAROON
PACIFIC BLUE	TERRA COTTA	SAND

This color chart is produced within the limitations of lithographic color printing and is intended as a general guide only.

ADP 300 Treatment Table



Ordering Information

Item#	Description
ADP 300 Treatment Table 28" x 75" (71 cm x 191 cm)	
ADP30000112	Imperial Blue
ADP30000212	Black
ADP30000412	Burgundy
ADP30000712	Dove
ADP30003312	Midnight
ADP30006112	Stone Blue

Switch Style (Suffix Table Item # with below Code)

F	Foot Switch
FC	Foot Switch & Retractable Castors
H	Hand Switch
HC	Hand Switch & Retractable Castors

Optional Accessories

60000	Table Paper Holder 20" (51 cm) Wide (TRT & ADP)
-------	---

Technical Specifications

ADP 400 Traction Table	
Mains Power:	120 V, 60 Hz
Current:	15 A
Power Input:	200 W
Weight:	140 lbs (64 kg),
Shipping Weight:	285 lbs (129 kg)
Lifting capacity:	400 lbs (181 kg)
Dimensions:	75"L x 28"W x 17.5" to 38"H (191 cm x 71 cm x 45 cm to 97 cm)
Electrical Safety Class:	Class 1, Type B

Color Options

ADP 300 Treatment Table		
BLACK	BURGUNDY	MIDNIGHT GRAY
DOVE	IMPERIAL BLUE	STONE BLUE

This color chart is produced within the limitations of lithographic color printing and is intended as a general guide only.



Features

ADP 300 Treatment Table

Adapta Treatment Tables' practical design lets practitioners do their best work without compromising patient comfort.

- Two (2) fully adjustable sections:
 - Head section: 30° to -90° (one finger control)
 - Foot section: 0° to 75°
- 400 lb (181 kg) maximum lift capacity
- Standard hand control for elevation
- Adjustable height range between 17½" to 38" (45 cm to 97 cm)
- Integrated rear casters
- Optional foot control
- Optional retractable front caster
- One-year warranty

Table Options

- Hand Switch or Foot Switch
- Retractable 3rd (front) Casters

ADDITIONAL ORDERING INFORMATION

Important: When placing an order, be sure to include the switch style to your table selection.

Example: To order a ADP300 Treatment Table your Item# will suffix the selected code from the Switch Style List in the ordering information listed on this page.

ADP30000212E = ADP 300 TREATMENT TABLE, BLACK, WITH FOOT SWITCH

For downloadable forms go to www.DJGlobal.com/chattanooga and click on the Service link.

NOTE: SEE PRICE LIST FOR FULL LIST OF PRODUCTS.

ADP 400 Traction Table



INCLUDED WITH THE TX ADP 400 TRACTION ACCESSORY PACKAGE



4759
TX Traction Unit



7050
TX-1 Flexion Stool



1410
Deluxe Universal
Belt System



7040
Saunders Cervical
Traction Device

Features

ADP 400 Traction Table

- Four sections
- Friction-free gliding lumbar section
- Turret mounted traction pedestal
- Head and foot sections incline up to 90°
- Head section lowers to 25°
- 400 lb (181 kg) lifting capacity
- Standard hand control
- Adjustable height range between 21.5" to 41.5" (55 cm to 105 cm)
- Optional foot control
- Optional retractable caster
- Available in six colors
- Traction unit sold separately
- One-year warranty

Table Options

- Hand Switch or Foot Switch
- Retractable 3rd (front) Casters

ADDITIONAL ORDERING INFORMATION

Important: When placing an order, be sure to include the switch style to your table selection.

Example: To order a ADP300 Treatment Table your Item# will suffix the selected code from the Switch Style List in the ordering information listed on this page.

ADP40000212E = ADP 400 TRACTION TABLE, BLACK, WITH FOOT SWITCH

For downloadable forms go to www.DJGlobal.com/chattanooga and click on the Service link.

NOTE: SEE PRICE LIST FOR FULL LIST OF PRODUCTS.

Ordering Information

Item#	Description
ADP 400 Traction Table	
ADP40000112	Imperial Blue
ADP40000212	Black
ADP40000412	Burgundy
ADP40000712	Dove
ADP40003312	Midnight Gray
ADP40006112	Stone Blue

Switch Style (Suffix Table Item # with below Code)

F	Foot Switch
FC	Foot Switch & Retractable Castors
H	Hand Switch
HC	Hand Switch & Retractable Castors

TX ADP 400 Traction Accessory Package

6874-1	Imperial Blue
6874-2	Black
6874-3	Burgundy
6874-4	Dove
6874-5	Midnight Gray
6874-6	Stone Blue
7050	TX-1 Flexion Stool

Optional Accessories

60000	Table Paper Holder 20" (51 cm) Wide (TRT & ADP)
-------	---

Technical Specifications

ADP 400 Traction Table	
Mains Power:	120 V, 50 Hz
Current:	1.6 A
Power Input:	200 W
Weight:	200 lbs (91 kg)
Shipping Weight:	320 lbs (145 kg)
Dimensions:	77"L x 27"W x 21.5" to 41.5"H (196cm x 69cm x 55cm to 105cm)
Electrical Class:	Class I, Type B

Color Options

ADP 400 Traction Table		
BLACK	BURGUNDY	MIDNIGHT GRAY
DOVE	IMPERIAL BLUE	STONE BLUE

This color chart is produced within the limitations of lithographic color printing and is intended as a general guide only.

TTFT-200 Fixed Height Traction Table

Ordering Information

Item#	Description
-------	-------------

TTFT-200 Fixed Height Traction Table

6840001	Imperial Blue
6840002	Black
6840004	Burgundy
6840007	Dove
6840033	Midnight Gray
6840061	Stone Blue

TTFT-200 Fixed Height Traction Accessory Package

6878-1	Imperial Blue
6878-2	Black
6878-3	Burgundy
6878-4	Dove
6878-5	Midnight Gray
6878-6	Stone Blue

Optional Accessories

60000	Table Paper Holder 20" (51 cm) Wide (TRT & ADP)
-------	---

Technical Specifications

TTFT-200 Fixed Height Traction Table

Mains Power:	120 V, 50 Hz
Current:	1.6 A
Power Input:	200 W
Weight:	230 lbs (104.5 kg)
Shipping Weight:	230 lbs (134 kg)
Dimensions:	77"L x 28"W x 19" to 38"H (196 cm x 71 cm x 48 cm to 97 cm)
Electrical Class:	Class 1, Type B

Color Options

TTFT-200 Fixed Height Traction Table

BLACK	BURGUNDY	MIDNIGHT GRAY
DOVE	IMPERIAL BLUE	STONE BLUE

This color chart is produced within the limitations of lithographic color printing and is intended as a general guide only.



INCLUDED WITH THE TTFT-200 TRACTION ACCESSORY PACKAGE



Features

TTFT-200 Fixed Height Traction Table

- Two sections
- Traction unit pedestal
- 350 lb (159 kg) working load capacity
- Fixed height of 32" (81 cm)
- Available in six colors
- One-year warranty

TTET-200 Electric Hi-Lo Traction Table



INCLUDED WITH THE TTET-200 TRACTION ACCESSORY PACKAGE



4759
TX Traction Unit



7050
TX-1 Flexion Stool



1410
Deluxe Universal
Belt System



7040
Saunders Cervical
Traction Device

Features

TTET-200 Electric Hi-Lo Traction Table

- Two sections
- Friction-free gliding lumbar section
- Traction unit pedestal
- 400 lb (181 kg) lifting capacity
- Adjustable height range between 19" to 38" (48 cm to 97 cm)
- Standard hand control
- Optional foot control
- Available in six colors
- Traction unit sold separately
- One-year warranty

Table Options

- Hand Switch or Foot Switch
- Retractable 3rd (front) Casters

ADDITIONAL ORDERING INFORMATION

Important: When placing an order, be sure to include the switch style to your table selection.

Example: To order a TTET-200 Traction Table your Item# will suffix the selected code from the Switch Style List in the ordering information listed on this page.

687000212E = TTET-200 TRACTION TABLE, BLACK, WITH FOOT SWITCH

For downloadable forms go to www.DJOglobal.com/chattanooga and click on the Service link.

NOTE: SEE PRICE LIST FOR FULL LIST OF PRODUCTS.

Ordering Information

Item#	Description
TTET-200 Electric Hi-Lo Traction Table	
687000112	Imperial Blue
687000212	Black
687000412	Burgundy
687000712	Dove
687003312	Midnight Gray
687006112	Stone Blue

Switch Style (Suffix Table Item # with below Code)

F	Foot Switch
FC	Foot Switch & Retractable Castors
H	Hand Switch
HC	Hand Switch & Retractable Castors

TTET-200 Traction Accessory Package

6876-1	Imperial Blue
6876-2	Black
6876-3	Burgundy
6876-4	Dove
6876-5	Midnight Gray
6876-6	Stone Blue

Optional Accessories

60000	Table Paper Holder 20" (51 cm) Wide (TRT & ADP)
-------	--

Technical Specifications

TTET-200 Electric Hi-Lo Traction Table	
Mains Power:	120 V, 50 Hz
Current:	1.6 A
Power Input:	200 W
Weight:	230 lbs (104.5 kg)
Shipping Weight:	230 lbs (134 kg)
Dimensions:	77"L x 28"W x 19" to 38"H (196 cm x 71 cm x 48 cm to 97 cm)
Electrical Class:	Class 1, Type B

Color Options

TTET-200 Electric Hi-Lo Traction Table		
BLACK	BURGUNDY	MIDNIGHT GRAY
DOVE	IMPERIAL BLUE	STONE BLUE

This color chart is produced within the limitations of lithographic color printing and is intended as a general guide only.

Ordering Information

Item#	Description
-------	-------------

TX® Traction Unit

4759 TX Traction Unit

Standard Accessories

48082 Patient Interrupt Switch

27465 Patient Data Cards (1x)

Traction Tension Parameters

TX® Traction Unit

Parameters	Min - Max	Increments
------------	-----------	------------

Traction Period 1 - 99 Minutes 1 Minute

Hold Period 0 - 99 Seconds 1 Second

Rest Period 0 - 99 Seconds 1 Second

Traction Tension 0-200 lb (0 kg/0 N) - (90kg/890 N) 1 lb (1 kg/5 N)

Progressive Steps 1 Step - 9 Steps 1 Step

Regressive Steps 1 Step - 9 Steps 1 Step

Technical Specifications

TTET-200 Electric Hi-Lo Traction Table

Mains Power: 100 - 240 V, 50/60 Hz

Power Consumption: 75 V

Current Consumption: 3.2 Amps Max

Weight: 30 lbs (14 kg)

Dimensions: 17.5" L x 9.5" W x 17.5" H (45 cm x 24 cm x 45 cm)

Safety Tests: IEC/UL/EN: 60661-1, 60601-1-2; CAN C22.2 No. 601.1-M90 w/A2; cETLus Listed

TX® Traction Unit



User Protocols



Clinical Library

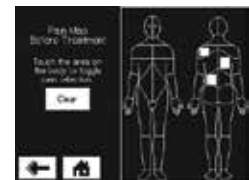

Pain Map

Features

TX® Traction

- Easy to operate
- 270° pivoting user interface
- Digital monochromatic touch screen interface
- Patient Data Cards record up to 14 treatment sessions
- Store up to 10 user defined protocols
- Intermittent, static and cyclic traction
- Progressive and regressive steps
- User-defined hold, rest and treatment times
- Traction tension parameters: 0-200 lbs
- Built-in safety features:
 - Patient Interrupt Switch
 - Cervical maximum poundage warning
 - Audible signal at the end of treatment and if Patient Interrupt Switch activates
- Two-year warranty

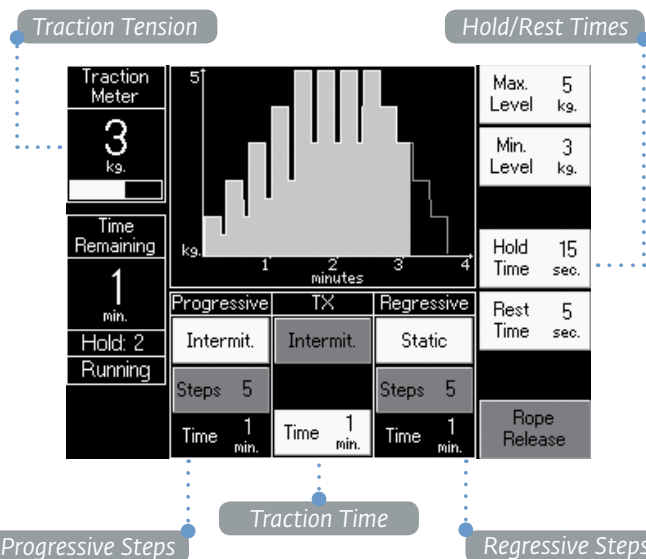

Progressive Steps

Traction Time

Regressive Steps

Traction Accessories



Features

A Mobile Traction Stand

- Fully adjustable
- Allows the TX Traction device to be used with most tables
- Traction unit sold separately

B Pron Pillo®

Elevates the head and shoulders for added comfort. The raised base allows patients in prone position to breath easier, adding greater patient comfort.

C TX Pillow and Cover

- Cervical pillow helps keep neck aligned naturally during traction or sleep
- Helps reduce strain on neck muscles

D Horseshoe Pillow

- Provides support for head and neck

E Traction Bolster Set

- Includes two knee bolsters and one ankle bolster
- Lightweight, eliminating the need for flexion stool
- Provides independent leg support

F Overdoor Traction Kit

- Over-the-door cervical traction kit, for patient administered flexion or extension cervical traction

Ordering Information

Item#	Description
A Mobile Traction Stand	
3600	Mobile Traction Stand
B Pron Pillo®	
4206	Pron Pillo
C TX Pillow and Cover	
1301	TX Pillow (without cover)
1341	TX Pillow cover
D Horseshoe Pillow	
83519	Horseshoe Pillow
E Traction Bolster Set	
42901	Traction Bolster Set
F Overdoor Traction Kit	
4390	Overdoor Traction Kit Includes overdoor pulley, water bag, and halter

Technical Specifications

Mobile Traction Stand

Length:	34" (86 cm)
Width:	27" - 40" (69 cm - 102 cm)
Height:	26" - 39.5" (66 cm - 100 cm)
Weight:	45 lb (20 kg)
Mounting Board:	12.75" x 10.5" (32 cm x 27 cm)

Ordering Information	
Item#	Description
Saunders® Cervical Traction	
7040	Saunders Cervical Traction Device: includes clevis for attachment to TX Traction Device
TXS-1 Flexion Stool	
7050001	Imperial Blue
7050002	Black
7050004	Burgundy
7050007	Dove
7050033	Midnight Gray
7050061	Stone Blue
Deluxe Universal Belt System	
1410	Deluxe Universal Belt System

Traction Accessories

Features

Saunders® Cervical Traction

This clinical unit pulls at the base of the occiput for more effective cervical traction. It adapts easily to all Chattanooga traction devices. One size fits most patients. One-year warranty.

Note: Clevis included to mount to traction device.



Features

TXS-1 Flexion Stool

Adjustable height from 13" to 20" (33 cm to 51 cm) feature allows you to place the patient's lumbar spine into neutral or flexed position for increased comfort. 90-day warranty.

Color Options		
TTET-200 Electric Hi-Lo Traction Table		
BLACK	BURGUNDY	MIDNIGHT GRAY
DOVE	IMPERIAL BLUE	STONE BLUE

This color chart is produced within the limitations of lithographic color printing and is intended as a general guide only.



Upholstery can be color-coordinated to match traction table.

Features

Deluxe Universal Belt System

- Designed with simplicity and quick setup in mind
- Universal fit wrap design with hook and loop closures
- Non-slip design allows for evenly distributed anterior/posterior pull force
- Allows you to wrap, set and start treatment in as little as 2 minutes
- 90-day warranty.



Saunders® Cervical Traction



Features

Safe

- A proven alternative to surgery for some patients
- Traction forces are directed to the back of the head to prevent compression of the TMJ
- Easy-to-read pressure gauge provides total control of the force at all times
- Blow-off valve limits the amount of force that can be applied

Effective

- A cost effective option to continuous clinical care
- Innovative design replicates clinical traction and promotes consistency of treatment
- Positioning alternatives allow varying treatment options for the clinician
- Patented pneumatic system ensures reliable force accuracy and leak-free performance

Easy to Use

- A portable treatment solution that increases patient compliance and satisfaction
- Patented self-adjusting neck wedges ensure a perfect fit
- Patented pump design incorporates a simple "click in place" mechanism
- Quick and simple patient set-up enables home traction without assistance



Ordering Information

Item#	Description
Saunders® Cervical Traction	
199594	Saunders Cervical Traction
Saunders® Lumbar Traction	
199603	Saunders Lumbar Traction

Ordering Information

Item#	Description
Saunders® Cervical Traction	
199594	Saunders Cervical Traction
Saunders® Lumbar Traction	
199603	Saunders Lumbar Traction

Saunders® Lumbar Traction



Features

Safe

- A proven alternative to surgery for some patients
- Friction-free surface ensures smooth motion
- Easy-to-read pressure gauge provides total control of the force at all times
- Blow-off valve limits the amount of force that can be applied

Effective

- A cost effective option to continuous clinical care
- Split table design replicates clinical traction and promotes consistency of treatment
- Actively moving treatment surface ensures efficient application of traction
- Patented pneumatic system ensures reliable force accuracy and leak-free performance

Easy to Use

- A portable treatment solution that increases patient compliance and satisfaction
- Comes complete — no assembly required
- Non-slip harnesses incorporate belt-organizers for quick set-up
- Patented pump design incorporates a simple “click in place” mechanism





DJO, LLC | A DJO Global Company
T 800.592.7329 **D** 760.727.1280 **F** 800.242.8329
1430 Decision Street | Vista, CA 92081-8553 | U.S.A.
DJOglobal.com/chattanooga