



EXOS FORM™ II 626/627

NOT TO BE USED FOR DJO BILLING PURPOSES

DOCUMENTATION WORKSHEET: RETAIN IN PATIENT RECORD

Doctor: _____ Fitter: _____

Patient Name: _____ Date: _____

Patient #: _____ Additional Follow-Up Dates: _____

TOOLS NECESSARY: Scissors • Heat Gun • Tape Measure • Exos Oven

CHECK APPROPRIATE BOX: Exos FORM II 626 Exos FORM II 627

PRODUCT COMPONENTS

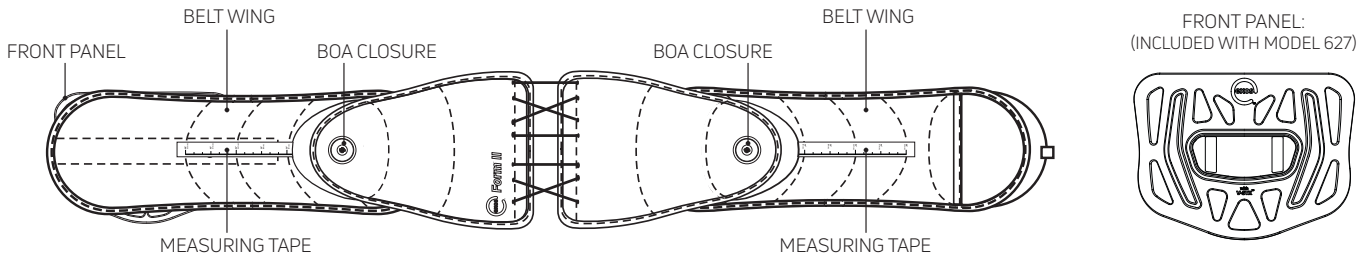

CLINICAL JUSTIFICATION FOR CUSTOMIZING BRACE

THIS PRODUCT IS INTENDED FOR APPLICATION BY A QUALIFIED INDIVIDUAL AS DIRECTED BY A PHYSICIAN OR OTHER QUALIFIED HEALTHCARE PROFESSIONAL. THIS IS A PREFABRICATED ORTHOSIS. IT IS INTENDED TO BE CUSTOMIZED TO AN INDIVIDUAL PATIENT. FOLLOW THE STEPS BELOW TO CUSTOMIZE.

STEP 1 - MEASUREMENTS

1 Lower rib circumference = _____

2 Hip circumference = _____

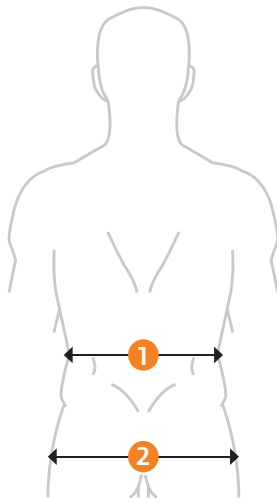

TIME SPENT: _____

STEP 2 - CUSTOMIZE LORDOTIC INSERTS TO ANATOMY

Heat form to patient's anatomy and contour to create intimate fit for individual lordosis.

- A. Remove the inserts from the Rear Panel Section.
- B. Heat inserts until malleable.
- C. Shape appropriately and let cool.
- D. Reinsert the inserts into the Rear Panel Section (Exos logo should be facing up and towards patient's back).

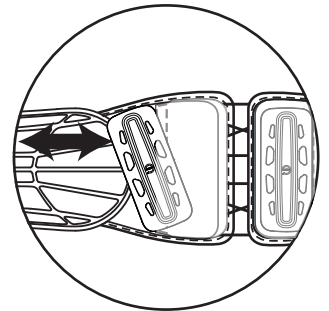

TIME SPENT: _____

STEP 3 - CUSTOMIZE SIZING

SIZING IS CRITICAL TO PROPER PERFORMANCE
Use the measurements below to customize to patient's anatomy.

- A. It may be necessary to adjust Belt Wing length by trimming. To customize the Belt Wing length:
 - 1. Use waist circumference (average of 1 and 2 _____) to determine proper sizing.
 - 2. Trim Belt Wing according to removable Measuring Tape.
- B. Add-on component (Front Panel) may require factoring in more Belt Wing length.

YES. AMOUNT CUT _____ NO

TIME SPENT: _____

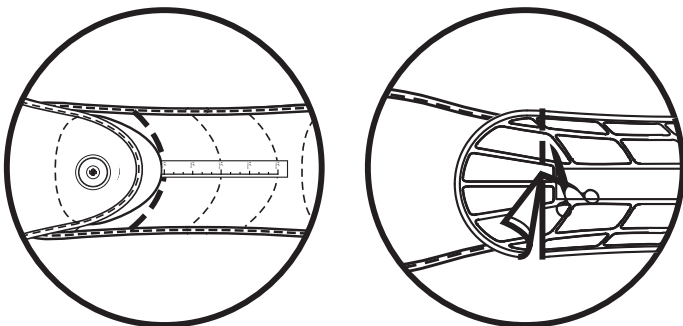



EXOS FORM™ II 626/627

NOT TO BE USED FOR DJO BILLING PURPOSES

DOCUMENTATION WORKSHEET: RETAIN IN PATIENT RECORD

Doctor: _____ Fitter: _____

Patient Name: _____ Date: _____

Patient #: _____ Additional Follow-Up Dates: _____

TOOLS NECESSARY: Scissors • Heat Gun • Tape Measure • Exos Oven

CHECK APPROPRIATE BOX: Exos FORM II 626 Exos FORM II 627

STEP 4 - MODIFY FRONT PANEL

MODIFY FRONT PANEL AS NECESSARY

TIME SPENT: _____

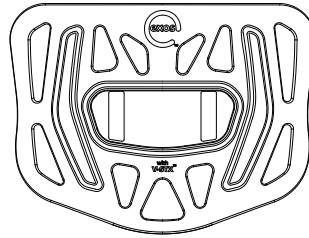

To customize Front Panel:

- A. Separate the panel from the Belt Wings and remove foam liner.
- B. Heat the panel until malleable.
- C. Shape appropriately and let cool.
- D. Reassemble.

STEP 5 - CUSTOMIZE BELT FIT

ANGLE BELT WINGS

Circumferential contact at both upper and lower margins of brace is essential for proper brace performance and support. Determine angulation for proper fit.

Angle Belt Wings:

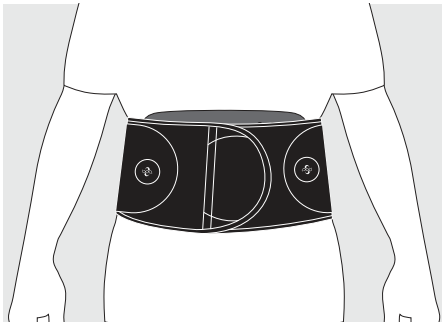

Neutral

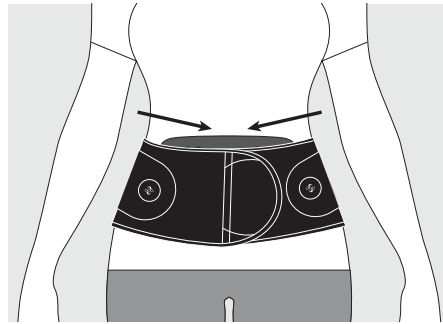

Inferior Angulation

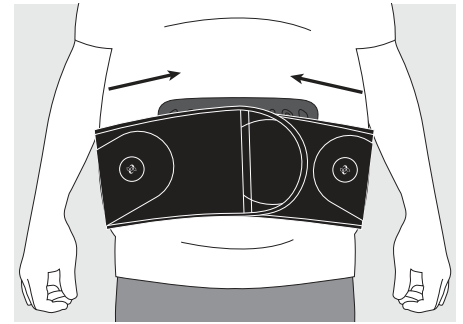

Superior Angulation

TIME SPENT: _____

STEP 6 - EDUCATION

EDUCATE PATIENTS

Proper education is needed for individual to maintain proper fit throughout total time of wear.

Items to educate patients on:

- | | | | |
|---|--|---|--|
| <input type="checkbox"/> BOA Closure System | <input type="checkbox"/> Proper angulation to ensure circumferential contact | <input type="checkbox"/> Proper cleaning | <input type="checkbox"/> Watch patient application video |
| <input type="checkbox"/> Don and doffing | <input type="checkbox"/> Proper placement of brace | <input type="checkbox"/> Follow up appointments | <input type="checkbox"/> Provide patient application instruction sheet |



TIME SPENT: _____

TOTAL TIME TO CUSTOMIZE BRACE: _____

For product assistance, please contact Product Support at 1-888-405-3251 or email product.specialist@djoglobal.com

DJO, LLC | A DJO Global Company
T 800.553.6019 F 760.683.6937
1430 Decision Street | Vista, CA 92081-8553 | U.S.A.
www.djoglobal.com

This clinical template is being provided to you by DJO as reference material only. The information included in this form has been adapted from the Medicare DMEPOS Quality Standards, available at <https://www.cms.gov/Medicare/Provider-Enrollment-and-Certification/MedicareProviderSupEnroll/Downloads/DMEPOS AccreditationStandardsCMB.pdf>. It is within the sole discretion of the customer to determine whether the use of a DJO product complies with medical necessity standards and meets all documentation requirements of the payor. DJO accepts no responsibility whatsoever in this regard, nor does DJO make claims, promises or guarantees as to the availability of reimbursement for any DJO product.